

MAXKOLD

**INSTALLATION
OPERATION AND SERVICE MANUAL**

SCROLL UNIT SERIES



Contents

Safety recommendations.....	3
Instructions for safe operation of the equipment.....	4
Specification and installation.....	5
Installation of condensing unit.....	6
Evacuation of system.....	6
Pressure test.....	6
Electrical connections.....	7
Important safety measures.....	7
Manual setting the maximum RPM	8
Maintenance.....	9
Circuit diagrams.....	10
Certification.....	11

Thank you for choosing MAXKOLD.

Please read these instructions carefully. They provide details and advice on the correct method of installing, using and maintaining this unit, in order to obtain maximum reliability, efficiency and a long life.

Safety recommendations

When installing and using the unit please follow the recommendations listed below.

- Installation shall be carried out in strict compliance with the diagrams and instructions supplied by the manufacturer.
- Damages due to improper connections are excluded.
- The electric system available where the unit is installed shall meet the relevant standards in force.
- Maintenance shall be effected by trained personnel or by the manufacturer according to the provisions supplied by EN378.

 **WARNING**
Use safety gloves to protect your hands from possible cuts and burns.

The user is strongly recommended to contact the manufacturer before attempting any interventions on the unit and any use not corresponding to the manufacturer's indications (in particular for the field of application) and to enquire about the possible dangers and contra-indications connected with an improper use of the machine.

The unit shall be used following these instructions and sticking to the destination of use indicated by the supplier. Any incorrect use can result in damages to the unit and could become a serious health hazard.

 **ATTENTION**
The unit is not suitable for working in explosive environments.
Therefore, the use of the unit in a flammable or unstable atmosphere is forbidden.

 **ATTENTION**
The unit is not suitable for working in salty environments.
In such a case, the condenser and evaporator must be protected with appropriate means.

When maintenance involves operations on the refrigerating circuit, you must empty the system and let it reach the atmospheric pressure.

 **WARNING**
Do not discharge the refrigerant into the atmosphere. It must be recovered by specialised technicians using suitable equipment.

- Quantity and quality of the refrigerant to be charged and indicated on the data plate.
- Do not use refrigerants of a different brand (especially inflammable fluids, e.g. hydrocarbons) or air.
- Do not modify or alter the refrigerating circuit or its components (e.g. welding on the compressor body)
- The final user shall protect the system from external fire dangers.

Instructions for safe operation of the equipment

1. Qualified technicians, who must refer to the electric schemes printed on the compressor, must attach the electrical connection of the condensing unit to the power supply.
2. In order to avoid damage, it is very important to remove all impurities (dirt, welding residuals, etc.) in the circuit before any work is begun.
3. Before starting the machine, it is necessary to make sure the system is correctly filled with refrigerant and that all valves are completely open.
4. It is not allowed to stand against an air outlet or stand on the top of a unit.

Emissions

This unit is in accordance with the European Union EMC Machinery Directive. There is no radioactive, poisonous or acidic material.

Specification and installation

Storage and transportation

Store the machine in a dry place in its original packaging. The storage temperature must be between -20°C and +60°C. Use the original packaging for transportation and handle with care.

Dimensional drawings & service valve sizes

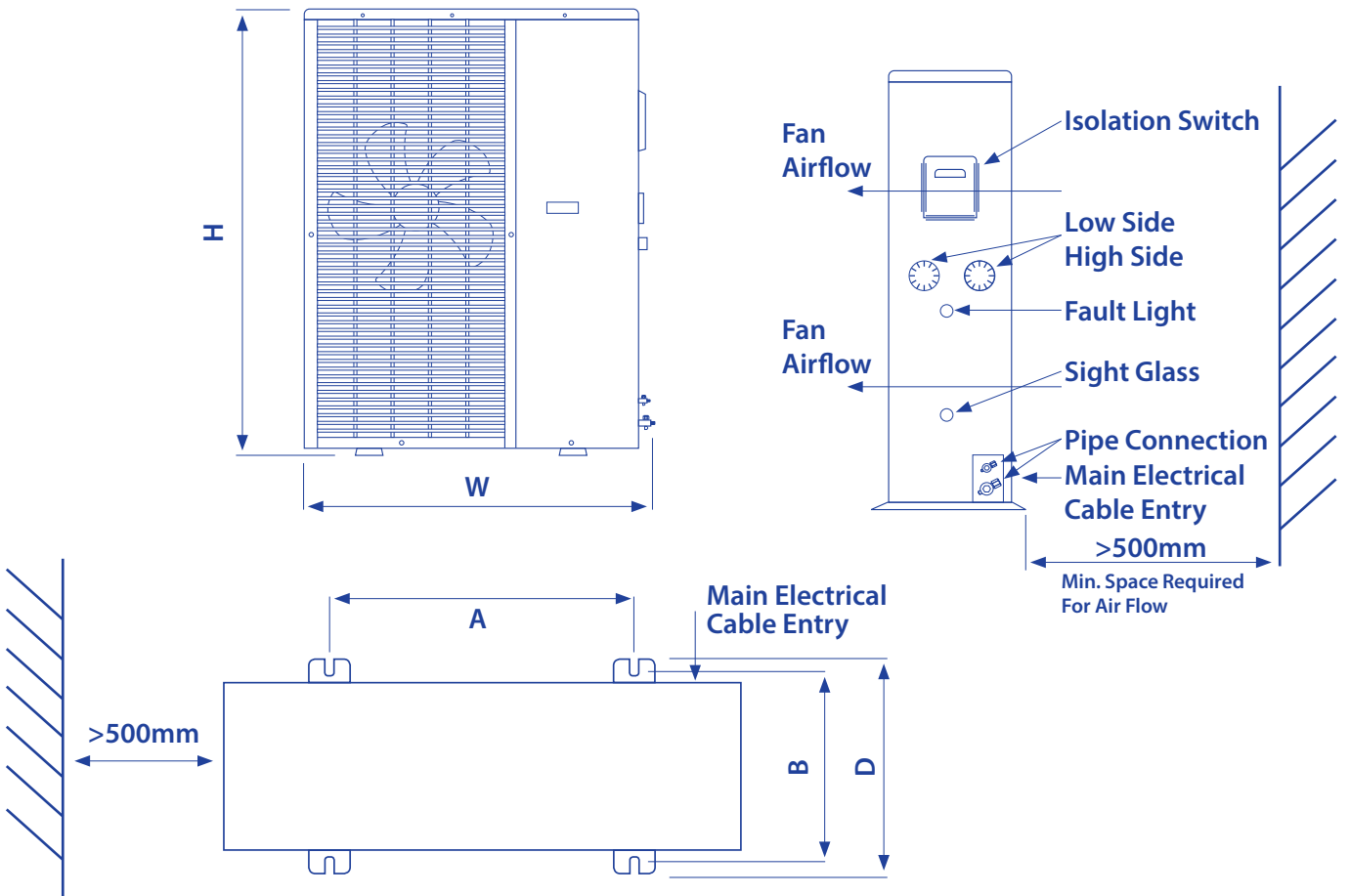

Service valve connections

Suction

NF200 – NF400 = 3/4"

NF500 – NF600 = 7/8"

Liquid

NF200 – NF300 = 3/8"

NF350 – NF600 = 1/2"

Model	Dimensions				
	Overall			Mounting hole	
	Height H (mm)	Width W (mm)	Depth D (mm)	A mm	B mm
NF200	844	1085	480	630	440
NF300	844	1085	480	630	440
NF400	844	1085	480	630	440
NF500	994	1085	480	630	440
NF600	994	1085	480	630	440



ATTENTION

Avoid exposing the condensing unit to direct sunshine.

When the unit is powered up, all panels must be closed.

Allow only qualified personnel to operate the unit.

Use refrigeration in accordance to the information printed on the machine's tag.



Installation of condensing unit

Before operating the unit, read and follow the instructions and warnings in this manual. The operator must be a trained professional in refrigeration systems, refrigerants, and the dangers of pressurized components. If the operator cannot read these instructions, operating instructions and safety precautions must be read and discussed in the operator's native language.

The user must dedicate the unit to only one type of refrigerant. Do not attempt to adapt the unit for another refrigerant. Do not mix refrigerant types through a system or in the same container; mixing of refrigerants will cause severe damage to the unit. Disconnect the power before servicing the unit.

General information

The condensing unit must be installed in a horizontal position and fixed using the fixing points, eventually adding anti-vibration materials as an intermediate layer.

Cleaning of the circuit

Use nitrogen gas in the pipes during the welding process. Use only materials and components that are specific for refrigerating circuits. Before starting, in order to avoid damage, it is very important to remove all impurities (dirt, welding residuals, etc.) in the circuit. These impurities can damage the compressor. In order to avoid this, an accurately dimensioned filter is already mounted on the suction line, this causes a very little pressure loss.

Evacuation of system

To obtain a regular operation the circuit must be evacuated to a pressure of at least 3 MPa, keeping the suction and liquid line valves closed. A correct evacuation lowers the relative humidity to 10 ppm.

Pressure test

Once the condensing unit has been connected to the circuit the suction and liquid line valves must remain closed during the test in order to avoid the entrance of air and humidity.

The pressure for this test, carried out with nitrogen, may not be higher than the one shown on the unit's tag. If the maximum working pressure that may be set by the controls and other components is lower than the specified value, limit the pressure to that value.

Electrical connections

Qualified technicians must refer to the electric schemes printed on the compressor when attaching the electric connection of the condensing unit to the power supply.

The choice of the main switch, contactors, single-pole switch, cross section and isolation of the wires must be made according to the rules in force and taking into consideration the electrical specifications stated on the machine's tag and enclosed documentation.

Note: the supply must range between $\pm 10\%$ from the value indicated on the machine's tag.

All compressors are equipped with a winding overheating protection. This protection consists of a klixon in the compressor, which interrupts the operation in case of excessive temperature.

Important safety measures

The unit must be earthed. The unit is to be serviced by trained personnel only. Please install the unit according to the wiring diagram.



CAUTION

Refrigerating compressors must be employed only for the use they are made for; only approved refrigerants and refrigerating oils may be used. Do not start the condensing unit if it is not connected to a refrigerating circuit or if it is not charged with refrigerant.

The unit may not be started if it isn't equipped with its calibrated safety controls. Furthermore, it is not advised to use the compressor to evacuate the circuit, in order to avoid damages to the motor.



Always close the panel that covers the electric connections before starting the machine to avoid the possibility of electrocution.

Before starting the machine it is necessary to make sure the system is correctly filled with refrigerant and that all valves are completely open.

If the refrigeration circuit contains air the "diesel effect" may occur, this is what happens when the air that enters in the compressor forms a mixture with the oil, which can explode and destroy the compressor with harm to persons nearby.

Even if correctly used, the compressor and the pressure line piping may reach temperatures that may cause burning if touched.



WARNING

If refrigerant escapes avoid contact with skin and eyes.

If the refrigerant needs to be removed from the system, don't disperse it into the environment, make sure to use specific equipment required for collecting the refrigerant.

Further information is available in our technical publications.

Calibration and settings of the regulation & safety components

Having completed the installation, it is necessary to verify the correct functioning of the regulation and safety components.

Manual setting the maximum RPM



CAUTION

Switch off electricity before operating.

Please open the DC fan controller box cover and find the RED code setting device on the PCB, and change the code position to get different maximum fan speed according to below table,

Gears	Code setting	RPM setting (single)	RPM setting (twin fans)
1	1=OFF, 2=OFF, 3=OFF, 4=OFF	600	510
2	1=ON, 2=OFF, 3=OFF, 4=OFF	620	526
3	1=OFF, 2=ON, 3=OFF, 4=OFF	640	543
4	1=ON, 2=ON, 3=OFF, 4=OFF	660	560
5	1=OFF, 2=OFF, 3=ON, 4=OFF	680	576
6	1=ON, 2=OFF, 3=ON, 4=OFF	700	593
7	1=OFF, 2=ON, 3=ON, 4=OFF	720	610
8	1=ON, 2=ON, 3=ON, 4=OFF	740	626
9	1=OFF, 2=OFF, 3=OFF, 4=ON	760	643
10	1=ON, 2=OFF, 3=OFF, 4=ON	780	660
11**	1=OFF, 2=ON, 3=OFF, 4=ON	800	676
12	1=ON, 2=ON, 3=OFF, 4=ON	820	693
13	1=OFF, 2=OFF, 3=ON, 4=ON	840	710
14	1=ON, 2=OFF, 3=ON, 4=ON	860	726
15	1=OFF, 2=ON, 3=ON, 4=ON	880	743
16	1=ON, 2=ON, 3=ON, 4=ON	900	760

** Factory default

Maintenance



ATTENTION

Disconnect the power supply before maintenance operations.

Oil and Oil level control

The oil used for refrigeration compressors is of a bright and transparent colour. It maintains its colour even after long operating periods. Eventual dark coloured shades are caused by impurities in the pipes or excessive temperature in the pressure part of the compressor and consequently decomposition of the oil, forming acids. The market offers special kits, which measures the acidity of the oil.

Every compressor is loaded with a sufficient oil quantity for normal operation. In larger capacity systems it might be necessary to add oil.

Filter drier

The unit is equipped with a humidity indicator. This makes it easy to determine if the filter must be replaced and the system checked for eventual leakage.

Initially it is recommended to check the humidity indicator every day, and later with longer intervals.

Condensers

Air-cooled condensers must be cleaned frequently because of air contamination, which flows through them. The fins may be cleaned with compressed air, possibly in opposite direction of the refrigerated airflow, or with chemical products to take the grease off.

Unsoldering the components of the system

In case of removal of the refrigerant, on the side of the high-pressure line, the low-pressure part of the compressor and the suction line may remain pressurized. If, in this case, a component situated on the low-pressure side is unsoldered, the pressurized mixture of oil and refrigerant may catch fire when brought into contact with the flame. It is therefore necessary to remove the refrigerant from both the high and low pressure side and check the pressure left with the help of a pressure gauge before unsoldering a component.

Circuit diagram

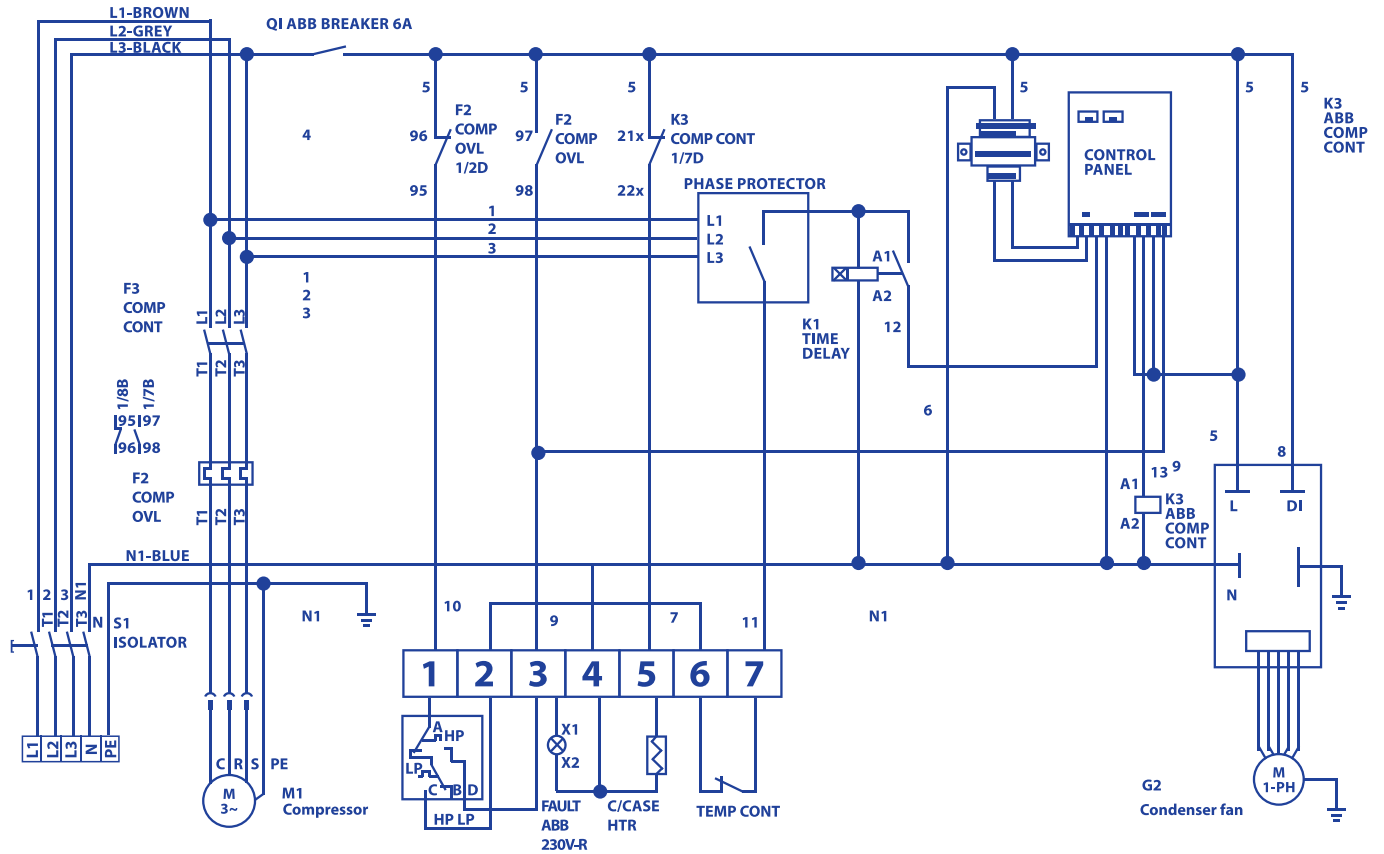

EU Declaration of Conformity

We

Maxkold Ltd
Unit 9i Kynoch Road, Edmonton, London, N18 3BD

Declare under our sole responsibility that the following product

Equipment: Condensing Unit
Brand name: Maxkold
Model/type: NFR075DL, NFR100DL, NFR150DL, NFR200DL, NFR250DL, NFR300DL, NFR350DL
NF200S, NF250S, NF300S, NF350S, NF400S, NF500S, NF600

is in conformity with the

Low Voltage Directive(LVD) 2006/95/EC
Electromagnetic Compatibility Directive(EMC) 2004/108/EC
Restriction of Hazardous Substances(RoHs) Directive 2011/65/EU
Commission Regulation(EU) 2015/1095

and the following harmonized standards and technical specifications have been applied:

LVD: EN 60335-1:2012
EN 60335-2-24:1999
EN 60335-2-24:200

EMC: EN 55011
EN 50081-2
EN 50082-2
EN 61000-4-2
EN 61000-4-3

RoHs: EN 50581 : 2013

The last two digits of the year in which the CE marking was affixed:13

21th of February,2019

Manufacturer: Maxkold Ltd

.....
Salih Hacimusa
Managing Director

MAXKOLD



Quality
build



Sales



Delivery



Quick
install



Technical
advice



Parts



Energy
efficient

Tel: 020 8997 0476 | Fax: 020 8997 1367 | www.maxkold.com | info@maxkold.com
Maxkold Limited, Unit 9i Eley Estate, Kynoch Road, Edmonton, London N18 3BD